

**SURVEYOR'S CERTIFICATE**

I, David F. McMullen, Wisconsin Registered Land Surveyor # S-1340, do hereby certify that I have surveyed and mapped the property shown hereon.

This survey was performed under the order of:  
Erik Johnson

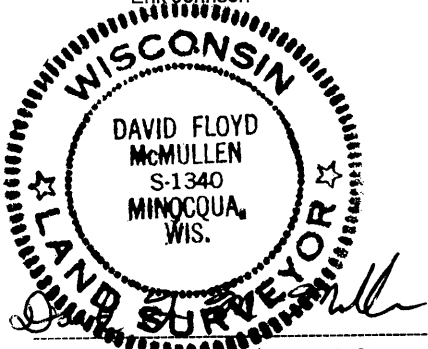

Registered Land Surveyor # S-1340

Date: 5/25/00

MCMULLEN & ASSOCIATES, INC.

Drafted By: Benton A. McMullen

Lots 13, 15, and 16  
of  
**HIXON WOODLANDS**  
Part of the  
NW 1/4 of the SE 1/4  
**SECTION 27, T 39 N, R 6 E**  
Town of Minocqua  
Oneida County, Wisconsin

L 1739

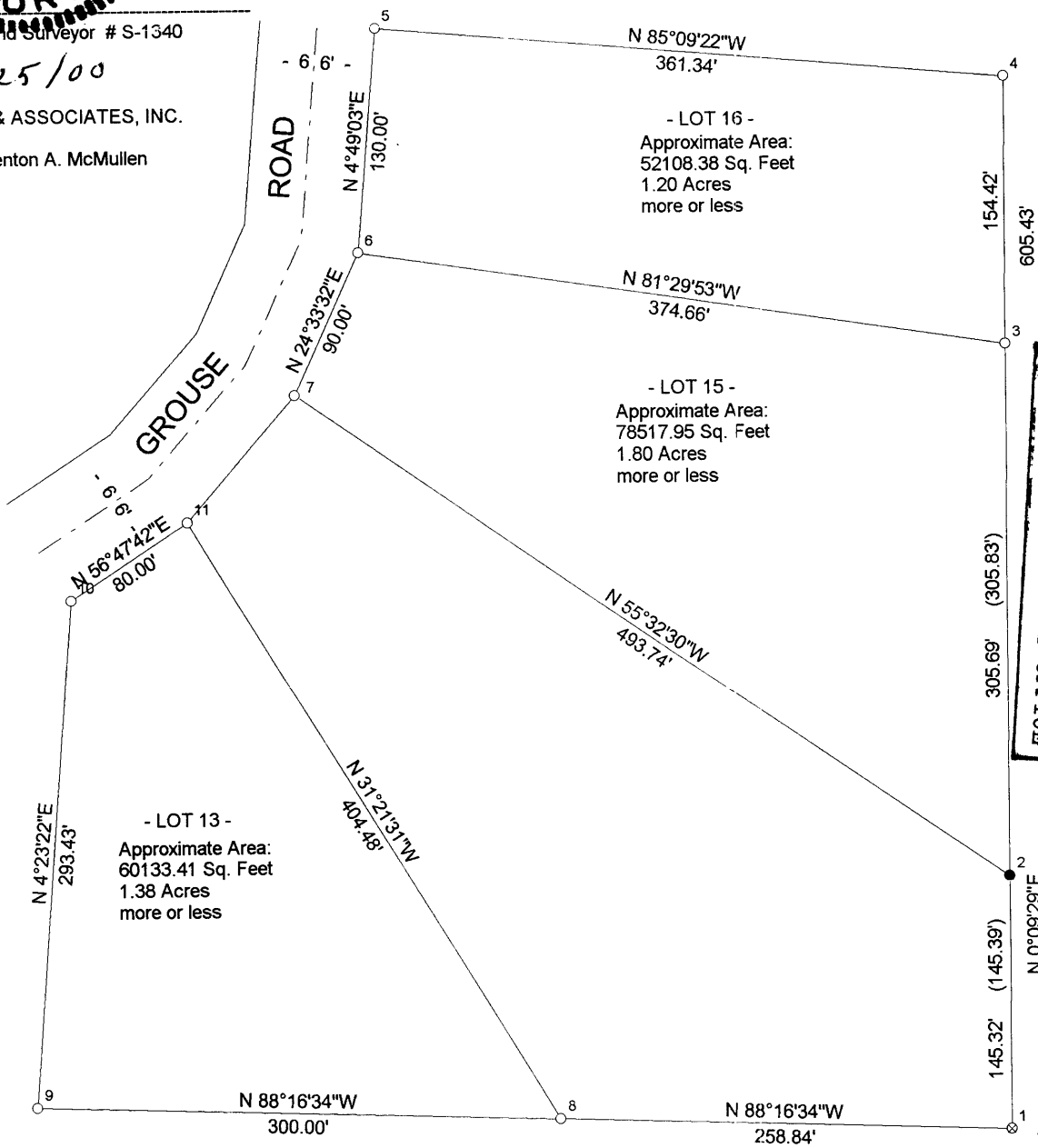

MAP # L 1739  
 DATE FILED JUL 21 2000  
 BY: [Signature]  
 DESCRIPTION FILED  
 ONEIDA CO. SURVEYOR'S OFFICE

**WAIVER**

This waiver is an agreement between ERIK JOHNSON (client) and DAVID F. MCMULLEN (surveyor), McMullen & Associates, Incorporated (company), to exclude/waive parts of the Minimum Standards for Property Surveys (Chapter A-E 7) of a line marking job performed on lots 13, 15, and 16 of Hixon Woodlands in the NW 1/4 of the SE 1/4, Section 27, Township 39, North, Range 6 East, in Oneida County, Wisconsin. The object of the line marking job was to flag the perimeter lines of the said lots.

The parts EXCLUDED/WAIVED from Chapter A-E 7 are as follows:

**A-E 7.03 BOUNDARY LOCATION.**  
- The surveyor shall make a field survey, traversing and connecting monuments necessary for location of the parcel and coordinate the facts of the survey with the analysis.  
- The surveyor shall set monuments marking the corners of the parcel unless monuments already exist at the corners.

**A-E 7.04 DESCRIPTIONS.**  
- Descriptions defining land boundaries written for conveyance or other purposes shall be complete, providing unequivocal identification of lines or boundaries.

**A-E 7.06 MEASUREMENTS.**  
- Measurements shall be made with instruments and methods capable of attaining the required accuracy for the particular problem involved.  
- The minimum accuracy of linear measurements between points shall be 1 part in 3,000 on all property lines of boundary or interior survey.  
- In a closed traverse the sum of the measured angles shall agree with the theoretical sum by a difference not greater than 30 seconds per angle, or the sum of the total angles may not differ from the theoretical sum by more than 120 seconds, whichever is smaller.  
- any closed traverse depicted on a property survey map shall have a latitude and departure closure ratio of less than 1 in 3,000  
- bearings and angles on any property survey map shall be shown to the nearest 30 seconds. Distances shall be shown to the nearest 1/100th foot.

The client realizes that the above line marking job performed is not an accurate survey and that there are no guaranties as to the position of the lines marked. The client also agrees to take full responsibility for any litigation caused by any possible errors in the lines marked. The client understands what is meant by the parts excluded from Chapter A-E 7 listed above.

Client Signature: [Signature]  
Surveyor Signature: [Signature]

Date: 5/29/00  
Date: 5/25/00

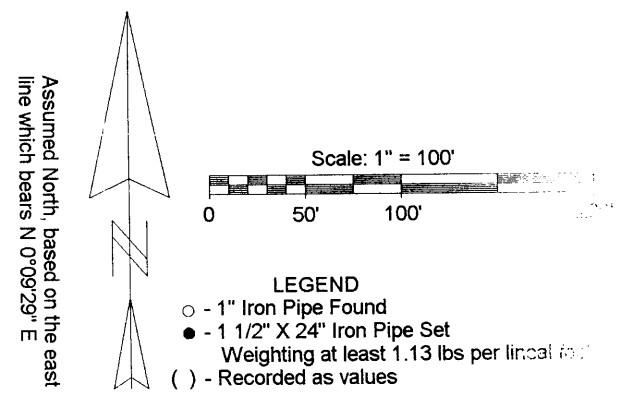

L 1739